

Keysight E4406A, E4440A, N9000A,
N9010A, and N9020A

E4406-60115 Standard Slide Kit

Notice.

The information contained in this document is subject to change without notice.

Keysight Technologies makes no warranty of any kind with regard to this material, including but not limited to, the implied warranties of merchantability and fitness for a particular purpose. Keysight Technologies shall not be liable for errors contained herein or for incidental or consequential damages in connection with the furnishing, performance, or use of this material.

Description

The Keysight E4406-60115 Standard Slide kit contains the parts and documentation needed to install the Keysight E4406A Transmitter Tester into an Keysight System (instrument) cabinet (345.4D & 421.6D).

Kit Contents:

Quantity	Description	Part Number
1 pair	Modified slides	
4	M5 x 20 Pan head screw (TORX)	0515-0688
4	M4 x 12 Pan head screw	0515-0909
4	M4 x 12 Flat head screw	0515-1013
8	M4 Unistrut nut	0535-0080
1	Installation Note	E4406-90047

Installation Procedure

1. Remove the side strap handles.
2. Attach slide (inner member) bracket to each side of the instrument using 2 M5 x 20 Pan head screws (0515-0688) per side.
3. Insert 2 Unistrut nuts in each of the 4 vertical columns (old HW racks).
4. Attach slide (outer member) to each side of the rack using 2 M4 x 12 Flat head screws (0515-1013) in front and 2 M4 x 12 Pan head screws (0515-0909) in the rear to the Unistrut nuts.

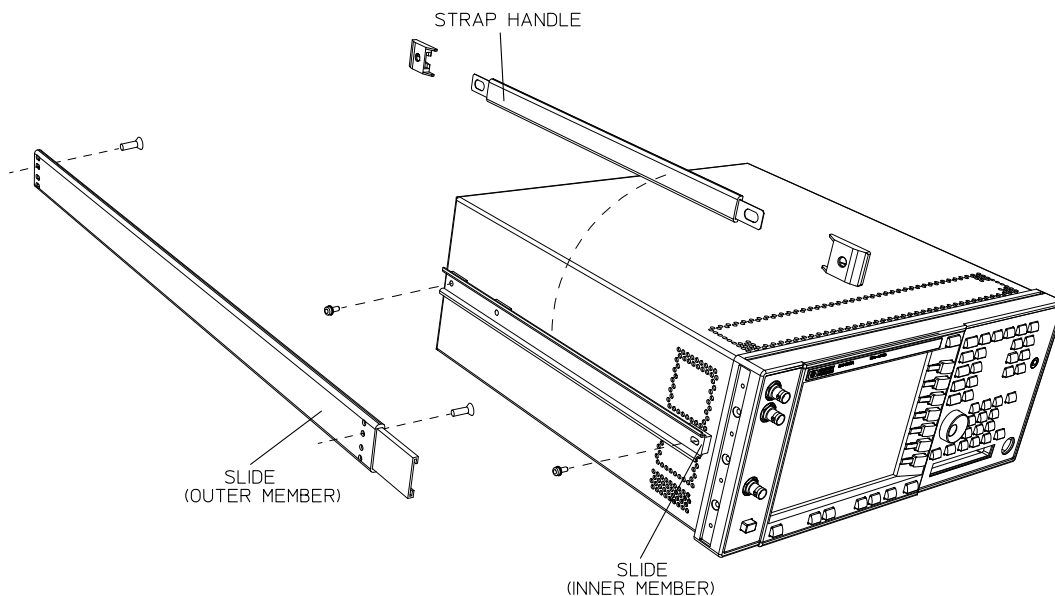

da81a



This information is subject to change without notice.

© Keysight Technologies 2015

Edition 1, February 2015

E4406-90047

www.keysight.com